



TECHNOLOGY BASED PACKAGING



Our innovative packages serve your great success

# Bliss pack

**Bliss**  
pack [www.blisspack.com](http://www.blisspack.com)

#### 본사 / Head office (Factory)

경기도 시흥시 경기과기대로 171  
171, Gyeonggigwagidae-ro, Siheung-si, Gyeonggi-do, Korea  
Tel : +82-31-495-2253 Fax : +82-31-495-2254  
E-mail : [overseas@blisspack.com](mailto:overseas@blisspack.com) (Overseas Sales Team) / [sales@blisspack.com](mailto:sales@blisspack.com) (Sales Team)

#### (株)プリスパック ジャパン / Tokyo office

東京都文京区湯島1-6-3 湯島一丁目ビル 802号室  
#802 Yushima 1chome bldg., 1-6-3 yushima, bunkyo-ku, Tokyo, Japan  
Tel : +81-3-6801-6589 E-mail : [sales@blisspack.co.jp](mailto:sales@blisspack.co.jp)

#### 博派实业(上海)有限公司 / Shanghai office

上海市闵行区吴中路1238号新盛商务大楼6层6D  
Room 6D, 6th Floor, Xinsheng Business Building, No.1238, Wuzhong Road,  
Minhang District, Shanghai, China, P.R.  
Tel : +86-21-5471-1771 E-mail : [sales@blisspack.com.cn](mailto:sales@blisspack.com.cn)

COPYRIGHT (C) 2018 BLISSPACK CO., LTD. ALL RIGHT RESERVED.

## PRODUCT GUIDE

[www.blisspack.com](http://www.blisspack.com)



## PRODUCTS OF BLISSPACK



### Blister packages

OEM production on consignment of blister packages for cosmetics and toiletries.

### Paper card type cosmetic samples

OEM production on consignment of blister packages for cosmetics, toiletries, households and etc.

### Freeze-drying products

Formulation, bulk production and freeze-drying for cosmetics

### Automatic blister packaging machine

Manufacture of fully automatic blister packaging and filling machinery.



## CHALLENGING TOMORROW, CREATIVE INNOVATION FOR THE WORLD

Blisspack is a R&D-oriented company that develops and studies blister packages, its packaging machines and freeze-drying products for cosmetics, toiletries and foods.

An exclusive supplier of blister package and freeze-dried cosmetics for Korean market, Blisspack is also supplying to global brands all around the world. Blisspack is opening a new dimension beyond the existing packages with innovative blister packages and advanced freeze-drying technology.

Blisspack's vision is to become a global leader of blister packages, freeze-drying solutions and to support customers to promote their value and notch.

Blisspack's innovative packages and technology will help customers to become a high-quality brand and provide lots of benefits for your customers to take a step forward to purchase your products.

Blisspack is here to help customers to develop more advanced personalized marketing and technical solutions to guide them to success.

We promise to do our best with unwavering truthfulness anywhere around the world.

블리스팩은 연구 개발 중심의 회사로 화장품, 생활용품과 식품용 블리스터 패키지와 그 포장 설비 그리고 동결건조 제품을 연구 개발하고 있습니다.

한국 시장에서 블리스터 패키지와 동결 건조 제품의 독점 공급업체인 블리스팩은 해외 글로벌 브랜드에도 공급을 하고 있으며,

창조적인 블리스터 패키지와 동결건조 기술로 기존의 패키지와 제품을 뛰어넘는 새로운 차원의 장을 열어가고 있습니다.

블리스팩의 비전은 블리스터 패키지와 동결건조 솔루션 분야를 선도하는 글로벌 리더가 되어 귀사의 가치와 급을 한 단계 더 끌어올릴 수 있도록 도움을 주는 것입니다.

블리스팩의 혁신적인 패키지 및 기술은 귀사를 최고의 브랜드로 거듭나게 하고, 귀사의 고객이 구매 결정을 하는 데 있어 한 발 나아갈 수 있는 많은 이점들을 선사할 것입니다.

귀사를 더욱 성공적인 길로 이끄는 첨단 마케팅 및 맞춤형 솔루션을 개발할 수 있도록 블리스팩이 함께 하겠습니다.

저희는 전 세계 어느 곳에서든지 변함없는 진실함으로써 최선을 다할 것을 약속 드립니다.





## R&D OF BLISSPACK

Carrying out continuous R&D investments that bringing cutting edge materials development, various technology and cosmetic development, Blisspack develops new products reflected needs from customers and introduce new products into market.

끊임없는 R&D 투자를 토대로 첨단 신소재 개발과 다분야 기술, 그리고 화장품 개발 등 다방면을 아우르는 개발·연구를 통하여 세계적인 신제품을 선보이고 고객의 요구를 반영한 고품질 제품을 개발합니다.

### FILM

- Easy peel film
- Easy tear film
- Aroma permeable film
- Barrier film

### CONVERTING

- Film laminating
- Distortion printing
- Other decorations

### FABRICATION

- Pre-half cut
- Steel rule die cut
- Instant action blister : two component mix

### MOLD

- Blister
- Injection molding
- Cutting tools
- Others

### MATERIAL

- Natural hydro-gel

### PACKAGE

- Sample card
- Prefilled syringe
- Air freshner blisters
- Pressure relief valve
- Eco-friendly package

### APPLICATION

- Cosmetics
  - Facial
  - Make up
  - Hair & Body care
  - Perfumes
- Toiletries

### MACHINERY

- Fully-automatic blister packaging machine
- Filling machine
- Other packaging machine
- Assembling line

### FREEZE DRYING

- No preservative
- Highly active factors
- Tailor-made
- DIY cosmetics

## PACKAGING TECHNOLOGY OF BLISSPACK

### Filling Technology

Blisspack packaging can be filled with six different liquid types at the same time with contents ranging from 0.2~50cc at a wide range of viscosity of 1~100,000 cps.

0.2 ~ 50cc의 액상 내용물의 정밀 충전이 가능 할 뿐 아니라, 6가지 서로 다른 내용물을 동시에 충전할 수 있으며, 1~100,000cps의 넓은 점도 영역의 내용물도 충전 가능합니다.

### Web Converting Technology

The blister sheet can be printed on in 8 colors with distortion printing method and can be supplied in sheet and film form with a suitable barrier structure to meet the customer's requirements for both bulk and small runs. The blister sheet can be manufactured in a form which is almost the same shape and design as the product.

Distortion 인쇄 기술로 8색까지 원단에 인쇄가 가능하고, 내용물 특성과 고객의 요구에 따라 패키지에 요구되는 차단성을 고려한 다양한 조합의 원단을 공급할 수 있으며, 본 제품의 형상과 디자인에 거의 일치하는 블리스터를 얻을 수 있습니다.

### Easy-peel Film Technology

The lid film on containers can easily peel-off with less power and excellent sealing properties at the same time.

적은 힘으로도 리드 필름을 벗겨낼 수 있으면서 우수한 밀폐성을 갖는 Peel-off 개봉에 매우 유용합니다.

### Fabrication Technology

The specially designed Half-cut line which enables easy opening of the break-off blister packages is suitable for packaging of low viscosity contents. The perforated line which has a beautiful appearance enables the separation of containers by tearing easily.

특수하게 디자인된 Half-Cut line은 블리스터의 Break-off 개봉을 가능하게 하며, 특히 점도가 낮은 내용물에 적합합니다. 또한 미려한 외관의 perforated line으로 각각의 용기를 쉽게 찢어서 분리할 수 있습니다.

### Mold Technology

A beautiful design of packaging can be obtained from relatively low mold cost will very effective in marketing.

상대적으로 저렴한 금형 비용으로 미려한 외관을 얻을 수 있어 마케팅에 매우 효과적입니다.

### Package Design

We have been recognized for competence and quality at various packaging awards around the world.

해외의 각종 패키징 어워드에서 뚜렷하게 두각을 드러내며 그 실력과 품질을 인정받았습니다.





## CONTENTS TECHNOLOGY OF BLISSPACK

Blisspack provides customers with global total solution ranging from ingredients development, formula development, packaging development, quality assurance to shipment for cosmetics.

Blisspack actively supports brand products development and production through the advanced unique technology and makes constant efforts to satisfy the customers from all over the world.

블리스팩은 화장품 분야의 내용물 제조, 처방 개발, 패키징 개발, 품질관리 그리고 출하에 이르기까지 글로벌 토탈 솔루션을 제공합니다.

블리스팩 고유의 기술을 통해 브랜드 제품 개발 및 생산을 적극적으로 서포트 하며 전 세계 고객사의 만족을 위해 끊임없이 노력하고 있습니다.

### Production 내용물 제조

Production facilities has been equipped in accordance with 1000 class clean room. And it is also equipped with suitable facilities for flexible manufacturing system for from small quantity batch production to mass production.

1000 Class Clean Room 규정에 맞는 생산 설비를 구축하고 있습니다. 또한 다품종 소량생산에서 대량생산에 이르기까지 적합한 설비를 보유하고 있습니다.

### Cosmetic Products 생산가능 품목

Basic cosmetics, Freeze-dried cosmetics, Make up, Hair care, Body care and Perfumes.

기초 화장품, 동결 건조 화장품, 색조 화장품, 헤어 제품, 바디 제품, 향수.

## Freeze Dried Cosmetics 동결건조 화장품

This is a solid cosmetic product that has been freeze-dried to create a low-moisture, preservative-free formula that can retain the effectiveness of active and functional ingredients.

It contains ingredients required by customers and the suitable formula for freeze dried cosmetics will be recommended.

1. It can be stored in dry condition so unstable ingredient in liquid solution can be compounded In the formula.
2. Preservatives can be controlled in very small amount.
3. It differentiates itself from existing cosmetics by appearance and conception.

제품을 급속 동결하여 저수분의 무방부제 처방으로 유효 성분과 기능성 성분의 효과를 유지할 수 있는 고품화 화장품입니다. 클라이언트가 원하는 성분을 함유하고 동결 건조에 적합한 처방을 제안합니다.

1. 건조상태로 저장할 수 있기 때문에, 용액 상태에서는 불안정한 원료를 안심하고 처방에 배합할 수 있습니다.
2. 방부제의 농도를 미량으로 억제할 수 있습니다.
3. 외관 및 개념에 대해 기존의 화장품과 차별화할 수 있습니다.

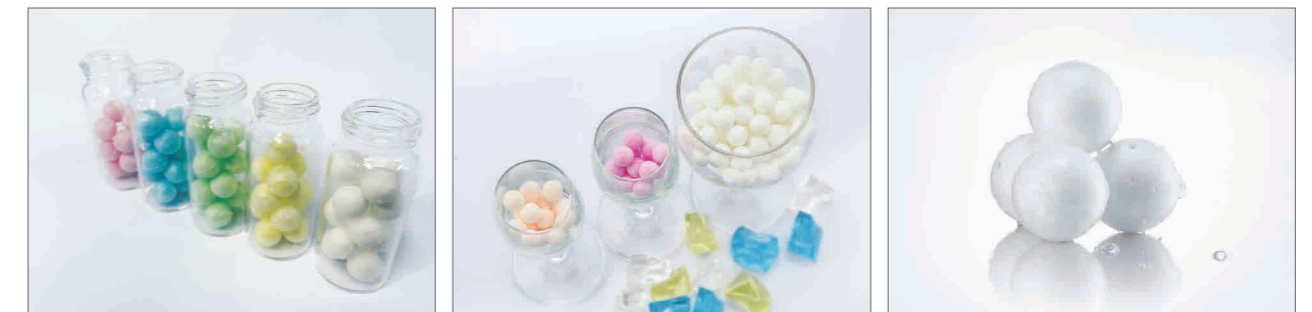

#### • What are freeze-dried cosmetics?

Low-moisture solid cosmetics without preservatives that have been freeze-dried to retain the effectiveness of active and functional ingredients.

#### • Benefits of freeze-dried cosmetics

- ⇒ New technology achieving that active ingredients for whitening and wrinkle-free are freeze-dried and stabilized in the product and the purity and potency of highly functional ingredients are brought to the highest level.
- ⇒ Free of skin irritating substances such as preservatives, mineral oil, silicone, synthetic oil, ethanol, artificial fragrance, and chemical additives.
- ⇒ New concept in DIY cosmetic that are formulated by each consumer right before their use so as to use only the freshest products.
- ⇒ Specially designed tailor-made products to fit the needs of each customer.

#### • 동결건조 화장품이란?

: 제품을 급속 동결하여 무방부제 처방으로 유효 성분과 기능성 성분의 효과를 유지할 수 있는 저수분의 고품화 화장품

#### • 동결건조 화장품의 장점

- ⇒ 미백, 주름개선 성분과 피부 활성 성분을 동결 건조하여 제품을 안정화 시키고 고기능성 성분의 순도와 역가를 최상의 상태로 끌어올린 기술
- ⇒ 방부제, 미네랄오일, 실리콘, 합성오일, 에탄올, 인공향, 화학첨가제 등의 피부 유해성분이 없는 화장품
- ⇒ 항상 신선한 새 제품을 쓸 수 있도록 소비자가 사용 직전에 만들어 쓰는 신개념 DIY 화장품
- ⇒ 고객 요구에 맞는 가능성을 부여할 수 있는 특화된 tailor-made 제품







## R&D AND MANUFACTURING PROCESS

Standardized cutting edge quality control system, excellent R&D staff 1000 class clean room and production facilities make it possible for Blisspack to provide products and service in accordance with global standards.

Development request → Business consultation (R&D: Ingredient development and proposal & Package development : Package development proposal) → Design development and sample production → Production schedule and sales strategy confirmation → Evaluation & confirmation → Contents and subsidiary material confirmation → Production → Q.C → Shipment

표준화된 품질관리 시스템과 우수한 연구진, 1000 Class Clean Room과 생산 설비 등으로 글로벌 기준에 맞는 제품과 글로벌 서비스를 제공합니다.

고객사 개발 의뢰 → R&D:내용물 개발 및 방향 제안 & 패키징 개발:패키징 개발 제안 → 디자인 개발 및 샘플 생산 → 생산 계획 및 판매 전략 설정 → 품평 및 승인 → 내용물 및 부자재 입고 → 생산 → Q.C → 출하



## QUALITY OF BLISSPACK

We have a strict quality control system for instilling trust in our clients by analyzing and controlling the safety, effectiveness, and stability of all processes from development, production and all the way to shipment.

클라이언트와의 신뢰를 위하여 철저한 품질 시스템을 갖추고, 개발단계에서부터 생산, 출하까지 모든 공정의 안전성, 유효성, 안정성 등을 분석 및 관리하고 있습니다.

**NOBLE  
QUALITY  
ASSURANCE**

- CGMP Certification
- ISO 9001, 22716 Certification (SGS Korea Co., Ltd.)
- QA Training & Education
- Complete Manufacturing Process
- High Products Quality
- Compliance to Agreed Specification
- Customer-Friendly
- Noble Reputation

**CUSTOMER'S  
IMPRESSION**





# PRODUCT GUIDE







### S001-12

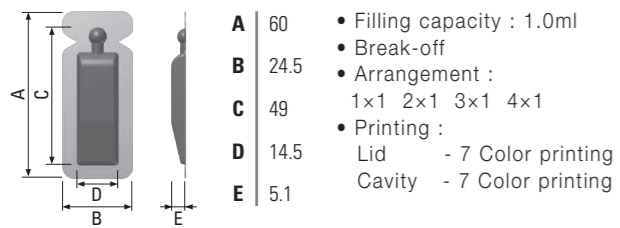

- Filling capacity : 1.0ml
- Break-off
- Arrangement : 1x1 2x1 3x1 4x1
- Printing : Lid - 7 Color printing  
Cavity - 7 Color printing

### S001B-12

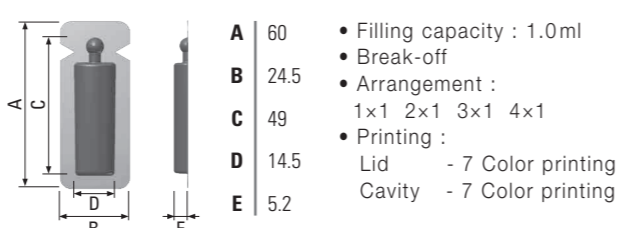

- Filling capacity : 1.0ml
- Break-off
- Arrangement : 1x1 2x1 3x1 4x1
- Printing : Lid - 7 Color printing  
Cavity - 7 Color printing

### S001(SO)-09

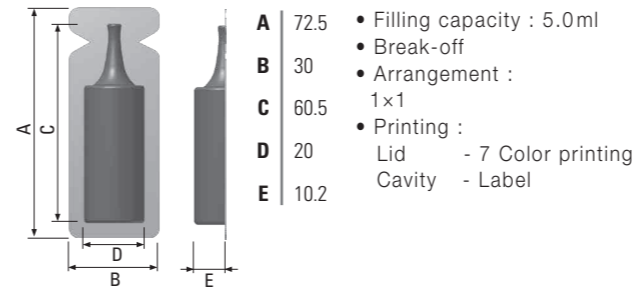

- Filling capacity : 5.0ml
- Break-off
- Arrangement : 1x1
- Printing : Lid - 7 Color printing  
Cavity - Label

### S003-12

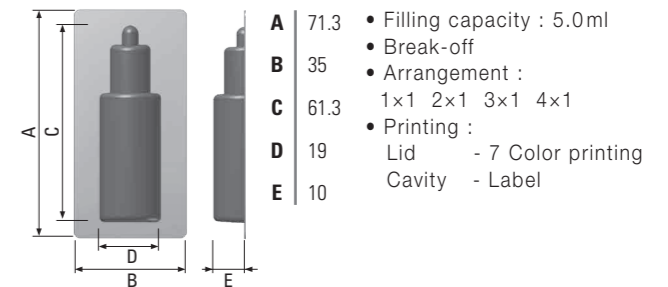

- Filling capacity : 5.0ml
- Break-off
- Arrangement : 1x1 2x1 3x1 4x1
- Printing : Lid - 7 Color printing  
Cavity - Label

### S001A-12

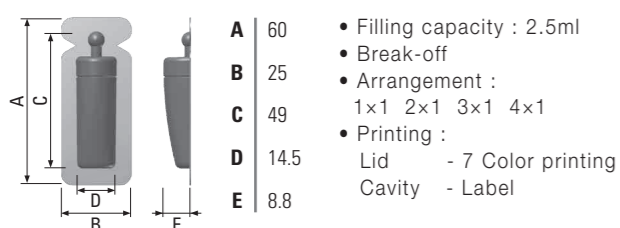

- Filling capacity : 2.5ml
- Break-off
- Arrangement : 1x1 2x1 3x1 4x1
- Printing : Lid - 7 Color printing  
Cavity - Label

### S005-16

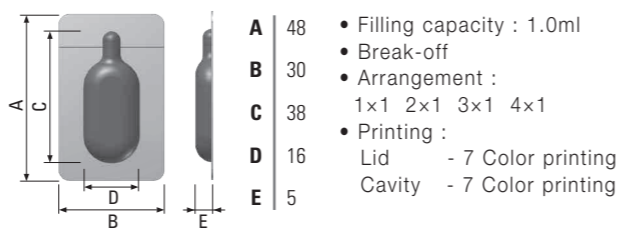

- Filling capacity : 1.0ml
- Break-off
- Arrangement : 1x1 2x1 3x1 4x1
- Printing : Lid - 7 Color printing  
Cavity - 7 Color printing

### S004-08

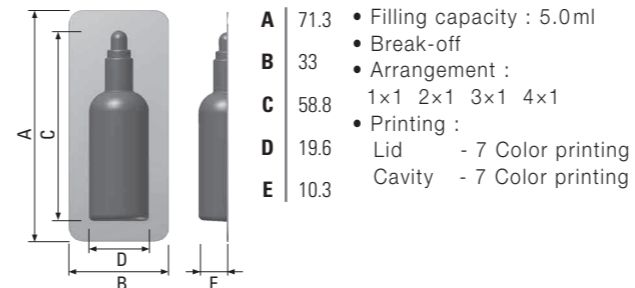

- Filling capacity : 5.0ml
- Break-off
- Arrangement : 1x1 2x1 3x1 4x1
- Printing : Lid - 7 Color printing  
Cavity - 7 Color printing

### S007-08

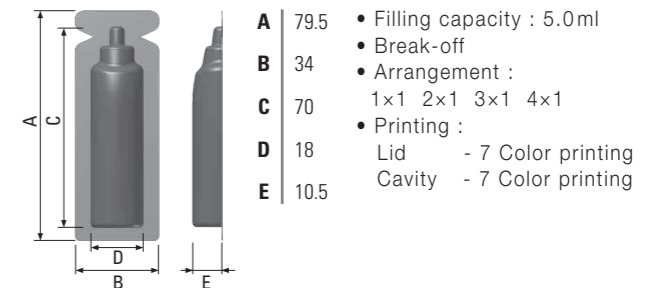

- Filling capacity : 5.0ml
- Break-off
- Arrangement : 1x1 2x1 3x1 4x1
- Printing : Lid - 7 Color printing  
Cavity - 7 Color printing

### S005A-16

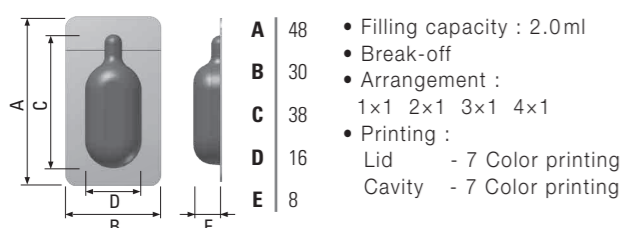

- Filling capacity : 2.0ml
- Break-off
- Arrangement : 1x1 2x1 3x1 4x1
- Printing : Lid - 7 Color printing  
Cavity - 7 Color printing

### S021-12

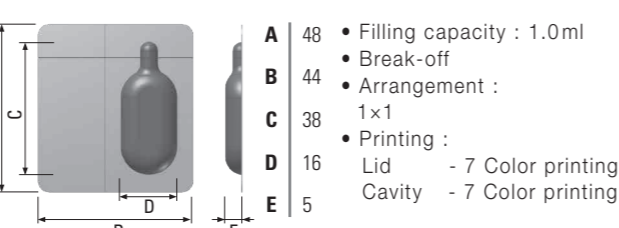

- Filling capacity : 1.0ml
- Break-off
- Arrangement : 1x1
- Printing : Lid - 7 Color printing  
Cavity - 7 Color printing

### S010-08

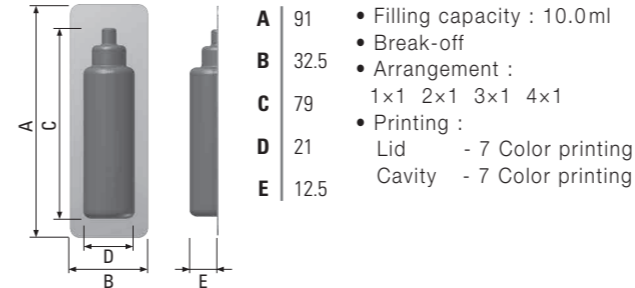

- Filling capacity : 10.0ml
- Break-off
- Arrangement : 1x1 2x1 3x1 4x1
- Printing : Lid - 7 Color printing  
Cavity - 7 Color printing

### S013(AP)-06

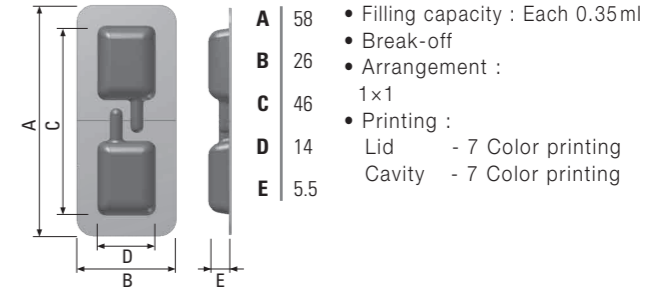

- Filling capacity : Each 0.35ml
- Break-off
- Arrangement : 1x1
- Printing : Lid - 7 Color printing  
Cavity - 7 Color printing





### S001(PS)-09

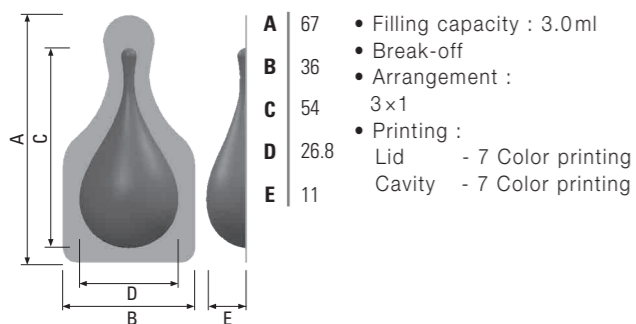

### S109-12

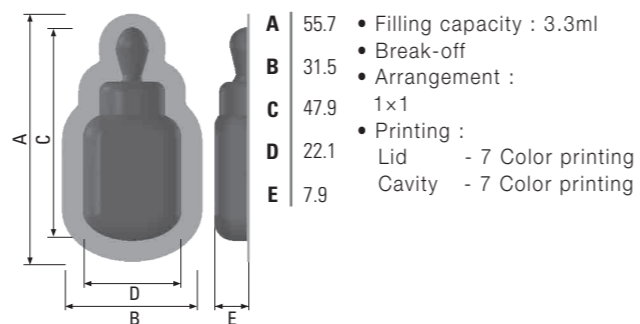

### P006A-09

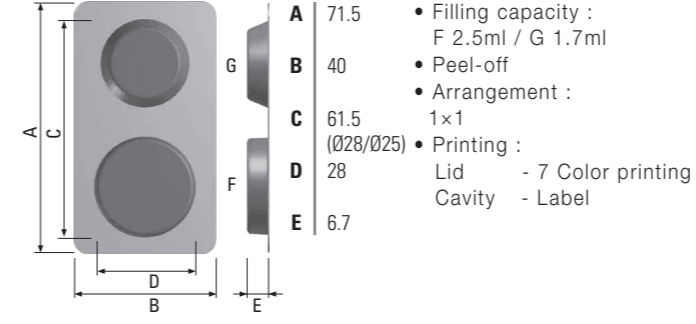

### P006B-09

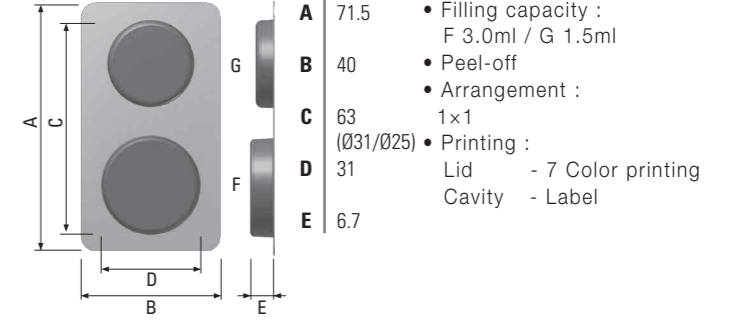

### P020-12

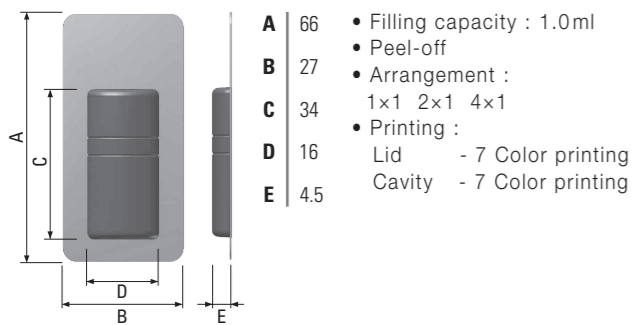

### P001(EL)-12

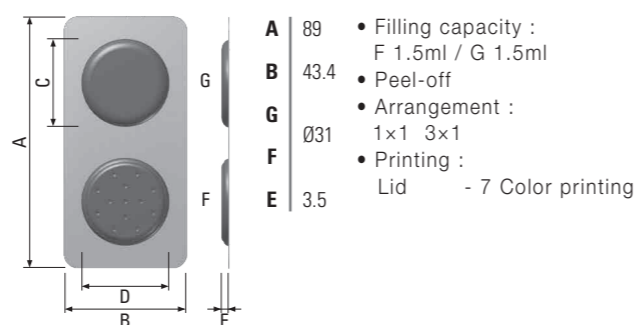

### P006-09

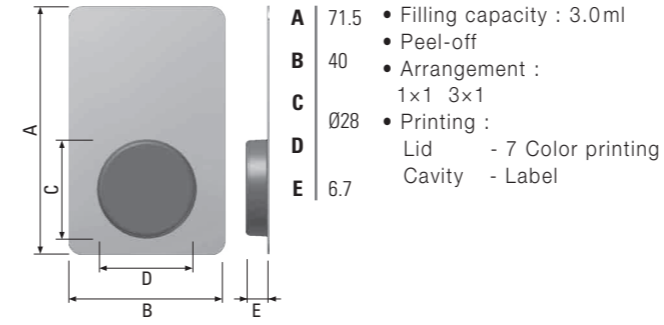

### P006C-09

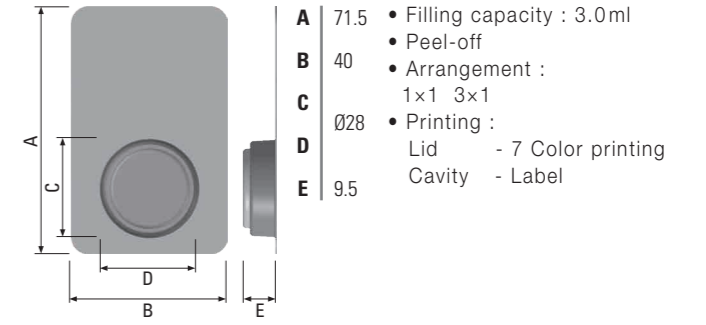

### P001A(EL)-12

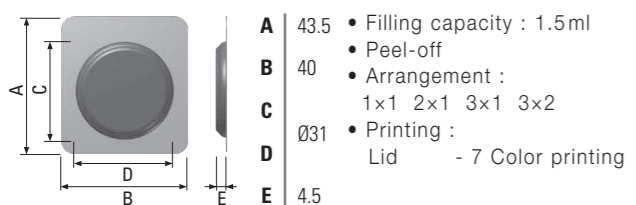

### P001(CN)-14

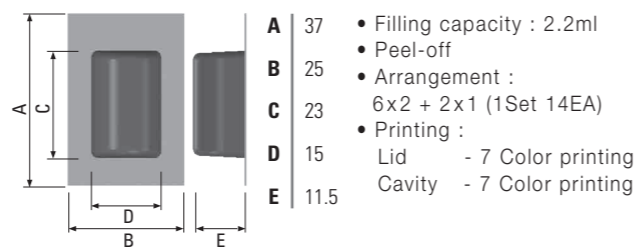

### P028-09(Coin Mask)

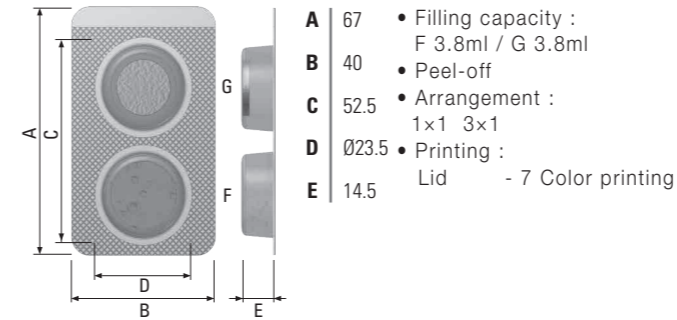

### P015(LG)-12

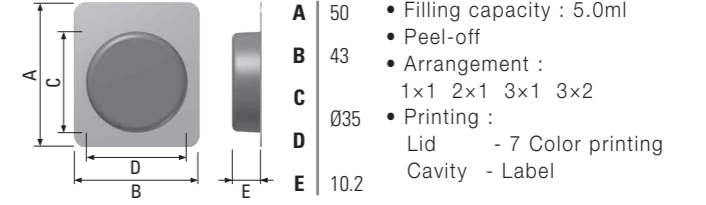





P019(AP)-16

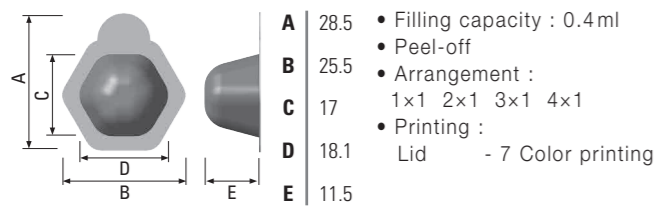

P029(AP)-12

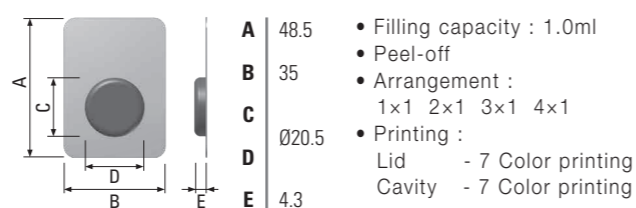

P011(AP)-12

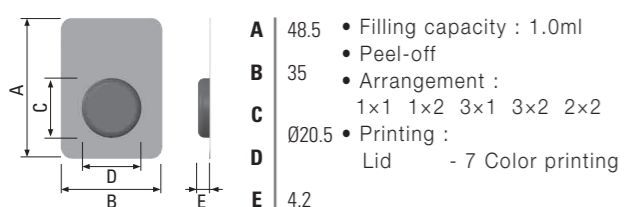

P011A(AP)-12

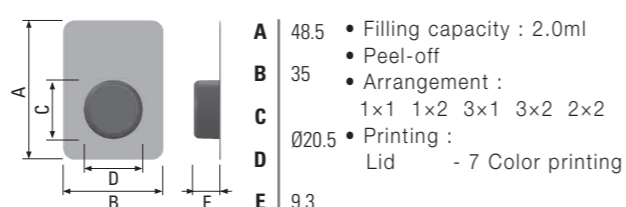

P011C(AP)-12

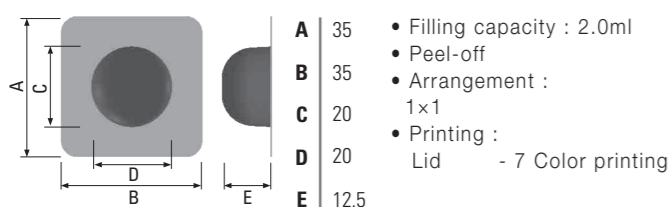

P011B(AP)-12

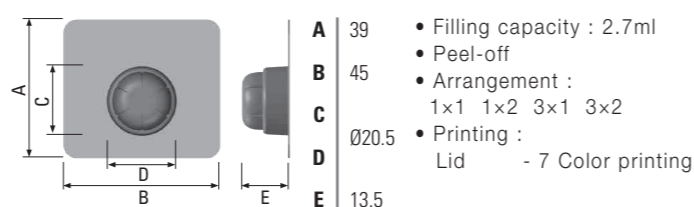

P011-24

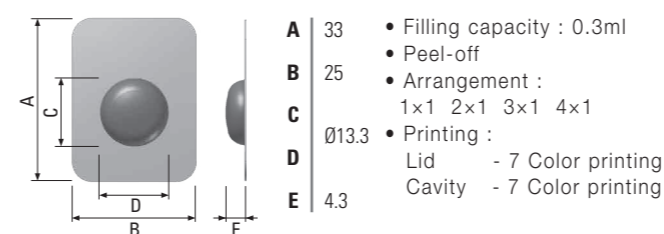

P011A-24

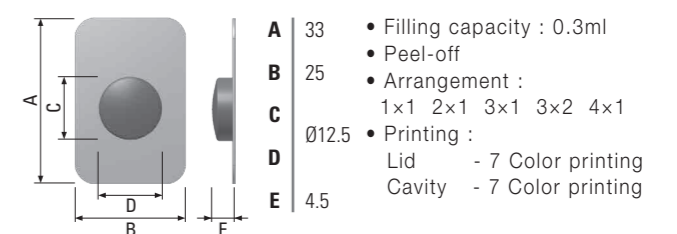

P005(LG)-12

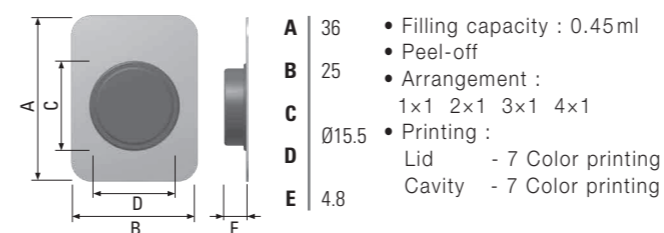

P010(AP)-12

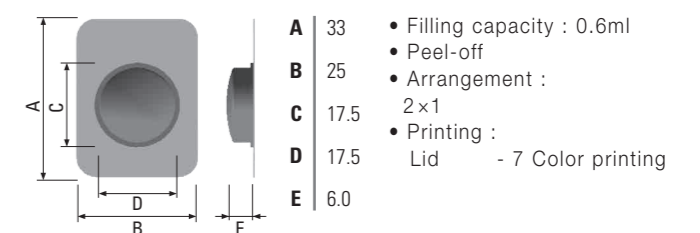

P017-24

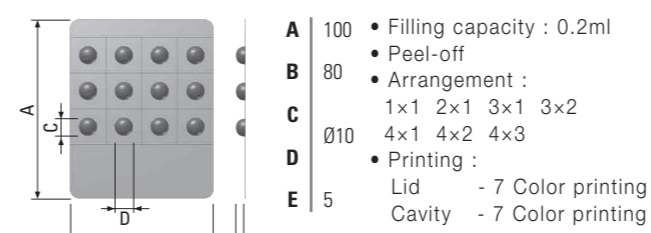

P017A-24

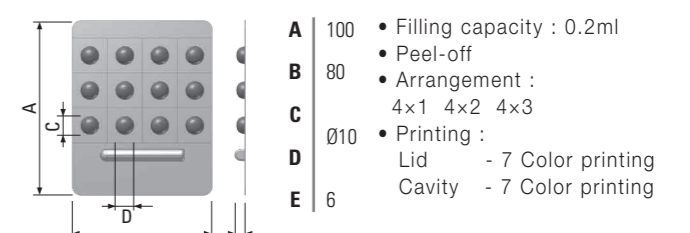

P027-12

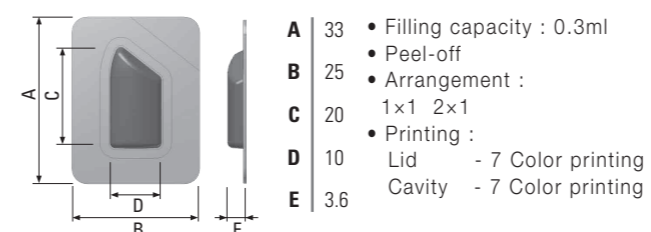





P002-08

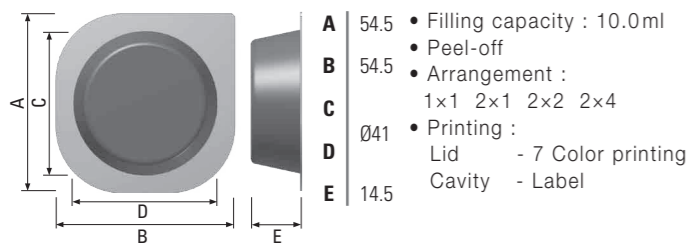

P009B-08

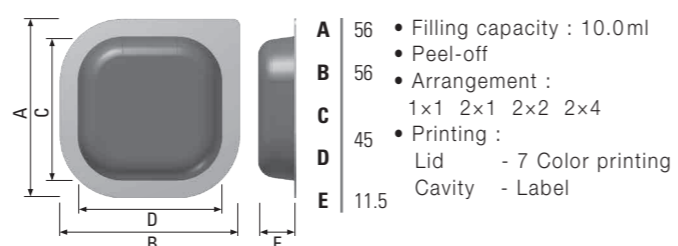

P024(AP)-16

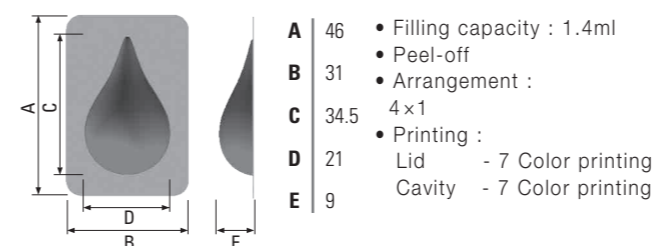

P008(AP)-08

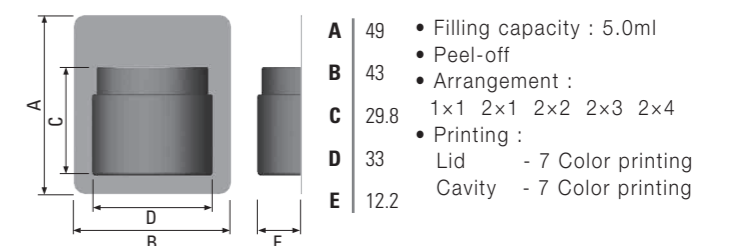

P009-08

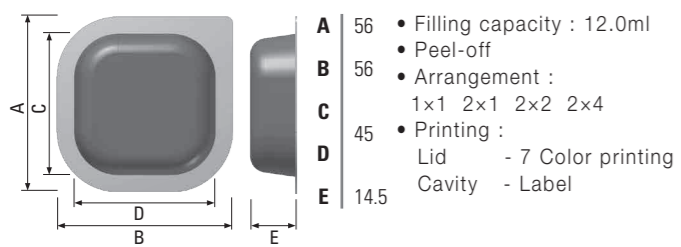

P009A-08

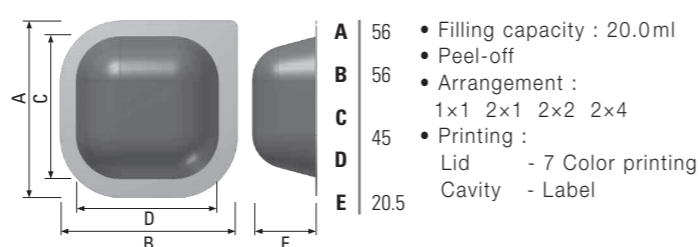

P038(AP)-12

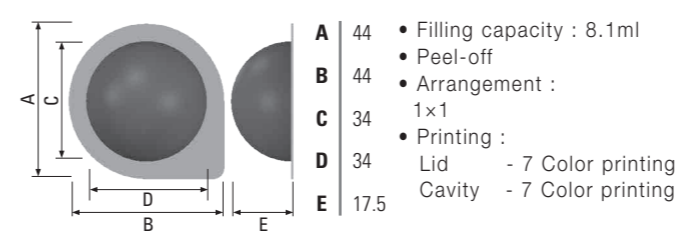

P002A-08

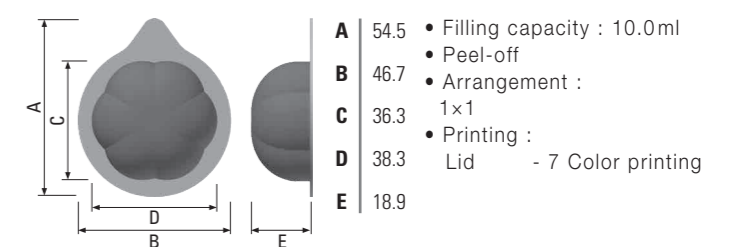

P014-06

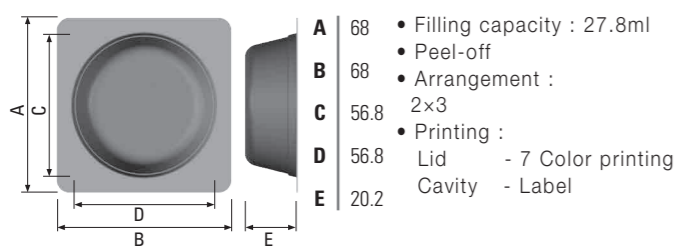

P013-03

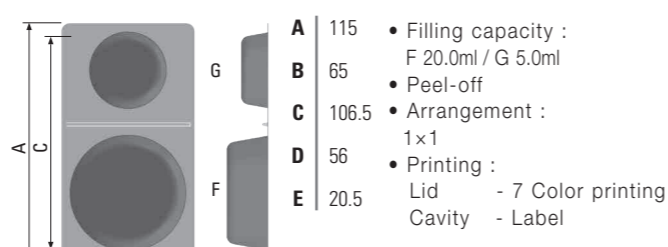

P001(HA)-06

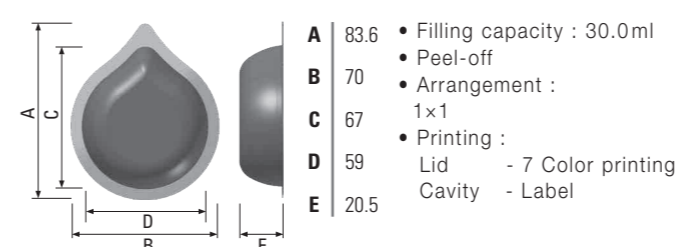

P019-06(Coin Mask)

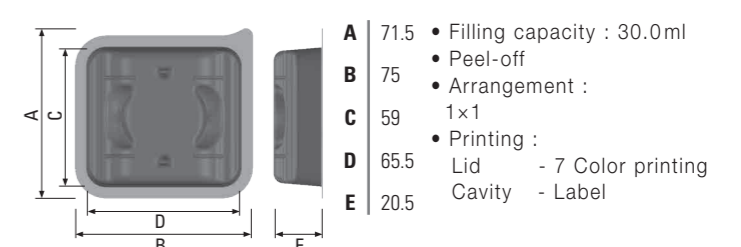





P040-08

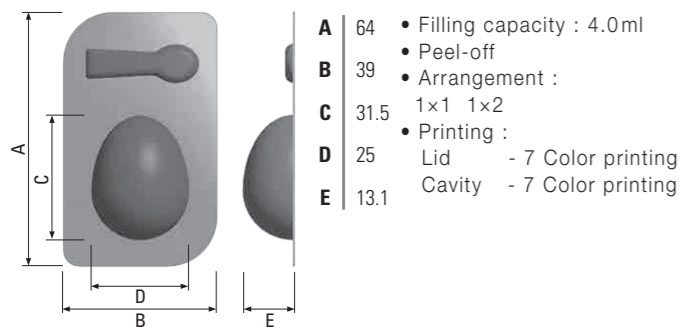

P041-08

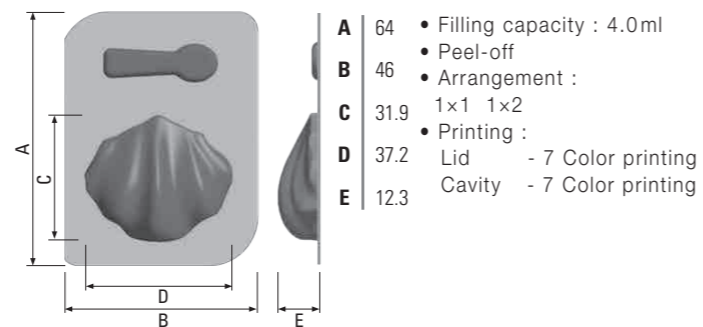

P042-03

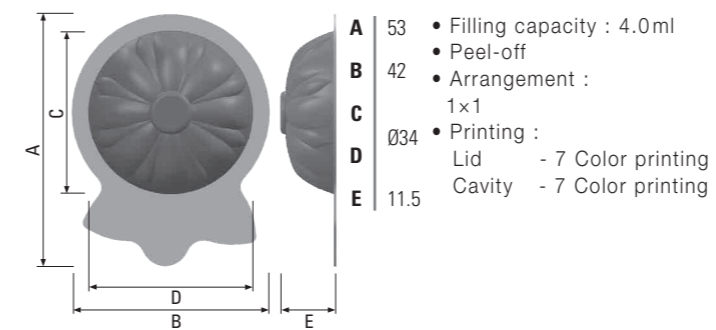

P042-03

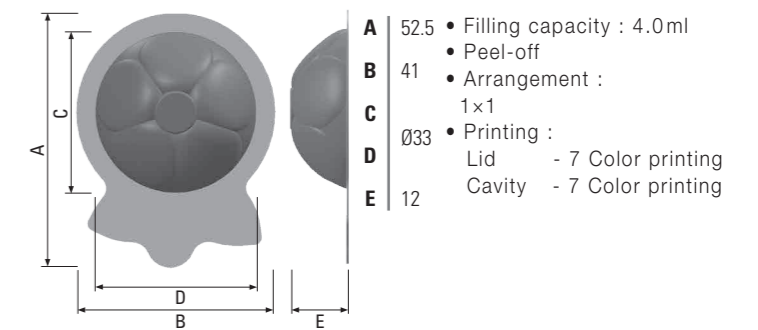

P038-02

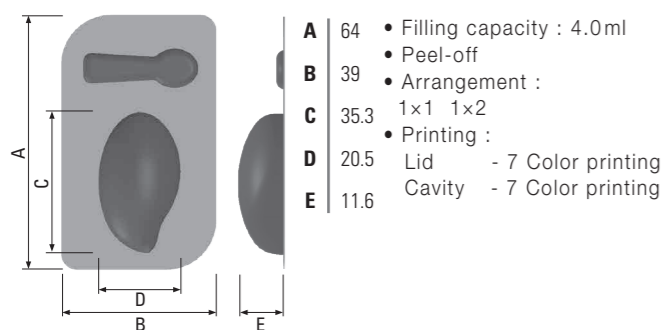

P114-08

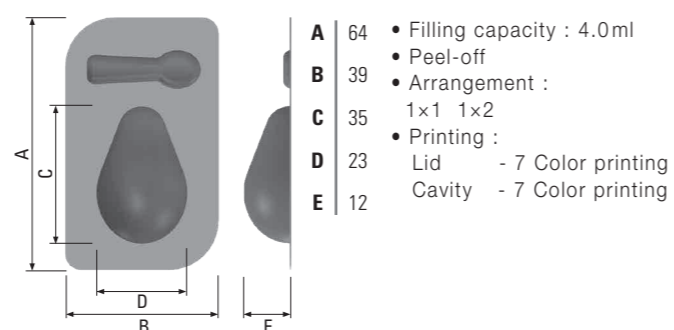

P042-03

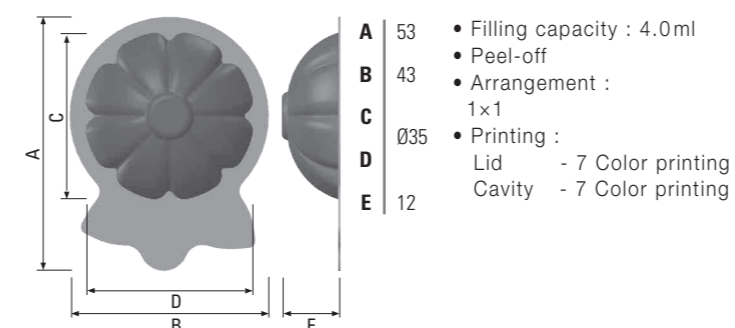

P042-03

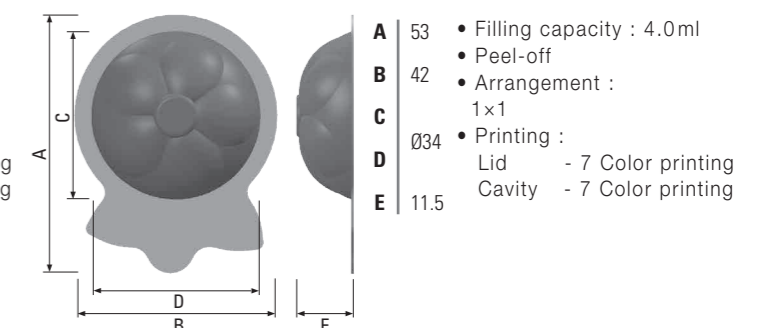

P034-06

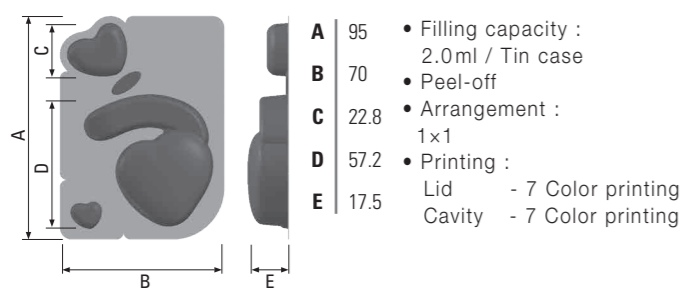





### P029A-04 (Re-sealable Blister – Eye Gel Patches)

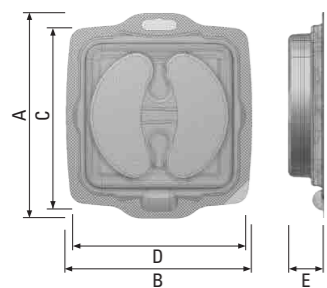

- |          |       |                      |                        |
|----------|-------|----------------------|------------------------|
| <b>A</b> | 116   | • Filling capacity : | 16 patches (8 sets)    |
| <b>B</b> | 104   | • Peel-off           |                        |
| <b>C</b> | 101.5 | • Arrangement :      | 1x1                    |
| <b>D</b> | 96    | • Printing :         | Lid - 7 Color printing |
| <b>E</b> | 17.5  |                      | Cavity - Label         |

#### How to use

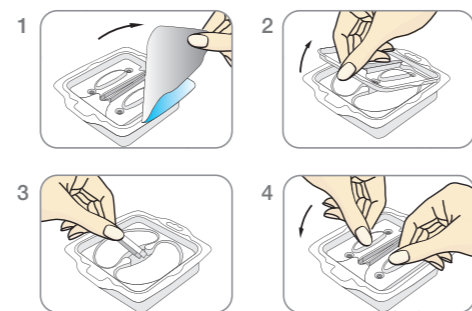

### P029B-04 (Re-sealable Blister – Mask Sheets)

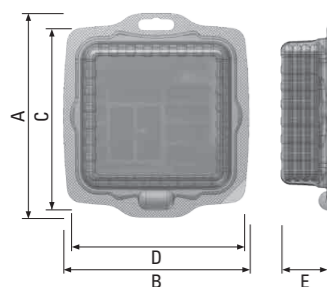

- |          |       |                      |                        |
|----------|-------|----------------------|------------------------|
| <b>A</b> | 116   | • Filling capacity : | 5 Sheets / 100ml       |
| <b>B</b> | 104   | • Peel-off           |                        |
| <b>C</b> | 101.5 | • Arrangement :      | 1x1                    |
| <b>D</b> | 96    | • Printing :         | Lid - 7 Color printing |
| <b>E</b> | 25.5  |                      | Cavity - Label         |

#### How to use

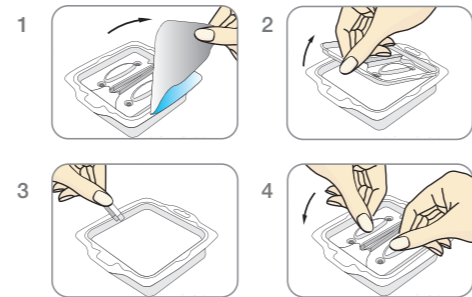

### P001(MS)-09

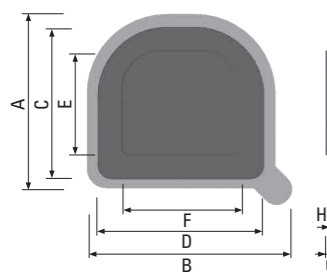

- |          |      |                      |                        |
|----------|------|----------------------|------------------------|
| <b>A</b> | 69   | • Filling capacity : | Pad / 1.0ml            |
| <b>B</b> | 74   | • Peel-off           |                        |
| <b>C</b> | 55   | • Arrangement :      | 1x1                    |
| <b>D</b> | 60   | • Printing :         | Lid - 7 Color printing |
| <b>E</b> | 38.1 |                      | Cavity - Label         |
| <b>F</b> | 43.1 |                      |                        |
| <b>G</b> | 4    |                      |                        |
| <b>H</b> | 2.5  |                      |                        |

### P012-08

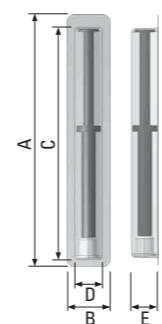

- |          |      |                      |                        |
|----------|------|----------------------|------------------------|
| <b>A</b> | 134  | • Filling capacity : | 1.0ml / max 1.5ml      |
| <b>B</b> | 23   | • Push cap :         | Blister(Peel off)      |
| <b>C</b> | 124  | • Arrangement :      | 1x1 2x1 4x1            |
| <b>D</b> | 16   | • Printing :         | Lid - 7 Color printing |
| <b>E</b> | 14.5 |                      |                        |

### 5ml Injection

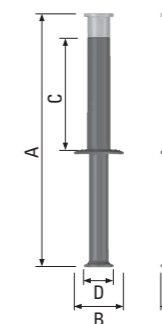

- |          |      |                      |                            |
|----------|------|----------------------|----------------------------|
| <b>A</b> | 150  | • Filling capacity : | 5.0ml                      |
| <b>B</b> | 29.7 | • Push cap           |                            |
| <b>C</b> | 66.3 | • Arrangement :      | 1x1                        |
| <b>D</b> | 17.5 | • Printing :         | Housing - 1 Color printing |
| <b>E</b> | 17.5 |                      | Piston - 1 Color printing  |

### P026-16

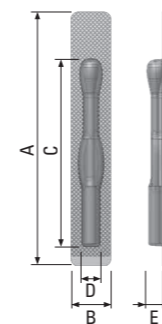

- |          |     |                 |                           |
|----------|-----|-----------------|---------------------------|
| <b>A</b> | 102 | • Cotton bud    |                           |
| <b>B</b> | 16  | • Peel-off      |                           |
| <b>C</b> | 75  | • Arrangement : | 1x1 2x1 4x1 8x1           |
| <b>D</b> | 10  | • Printing :    | Lid - 7 Color printing    |
| <b>E</b> | 7.2 |                 | Cavity - 7 Color printing |

### P022-04

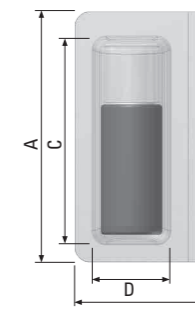

- |          |      |  |  |
|----------|------|--|--|
| <b>A</b> | 68.5 |  |  |
| <b>B</b> | 100  |  |  |
| <b>C</b> | 56.5 |  |  |
| <b>D</b> | 21   |  |  |
| <b>E</b> | 19   |  |  |

- Bottle for tester
- Peel-off
- Arrangement : 1x1
- Printing : Lid - 7 Color printing / Cavity - 7 Color printing

### P015-03

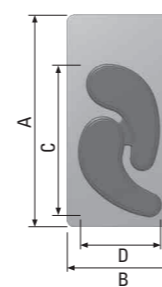

- |          |       |                      |                           |
|----------|-------|----------------------|---------------------------|
| <b>A</b> | 140   | • Filling capacity : | Each 2.5ml                |
| <b>B</b> | 70    | • Peel-off           |                           |
| <b>C</b> | 100.6 | • Arrangement :      | 1x1                       |
| <b>D</b> | 54.7  | • Printing :         | Lid - 7 Color printing    |
| <b>E</b> | 5     |                      | Cavity - 7 Color printing |





### M025-08

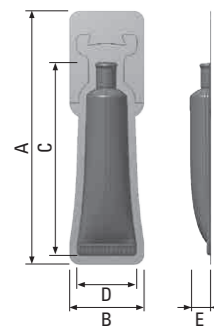

- |          |     |                            |
|----------|-----|----------------------------|
| <b>A</b> | 108 | • Filling capacity : 5.0ml |
| <b>B</b> | 33  | • Multi use                |
| <b>C</b> | 82  | • Arrangement :            |
|          |     | 1x1 2x1 3x1 4x1            |
| <b>D</b> | 25  | • Printing :               |
| <b>E</b> | 9   | Lid - 7 Color printing     |
|          |     | Cavity - 7 Color printing  |

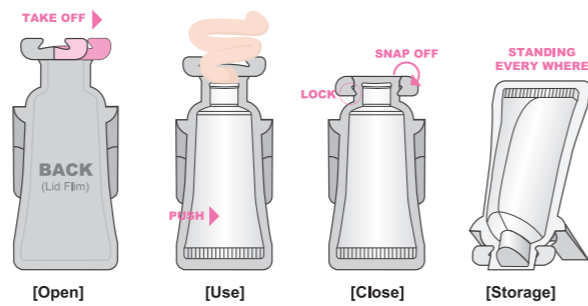

### A016A-09(Instant Action Blister-Essence Powder)

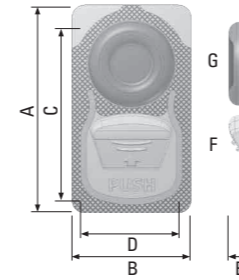

- |          |     |                        |
|----------|-----|------------------------|
| <b>A</b> | 67  | • Filling capacity :   |
|          |     | F 1.0ml / G 2.9ml      |
| <b>B</b> | 38  | • Action               |
| <b>C</b> | 48  | • Arrangement :        |
|          |     | 1x1 3x1                |
| <b>D</b> | 28  | • Printing :           |
| <b>E</b> | 8.5 | Lid - 7 Color printing |

### A106-12

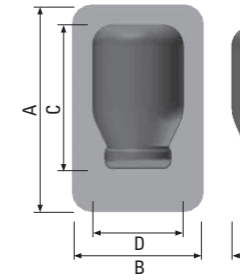

- |          |      |                            |
|----------|------|----------------------------|
| <b>A</b> | 51.1 | • Filling capacity : 3.0ml |
| <b>B</b> | 32.4 | • Action                   |
| <b>C</b> | 35.6 | • Arrangement :            |
|          |      | 1x1                        |
| <b>D</b> | 22.5 | • Printing :               |
| <b>E</b> | 9.7  | Lid - 7 Color printing     |
|          |      | Cavity - 7 Color printing  |

### M024-06

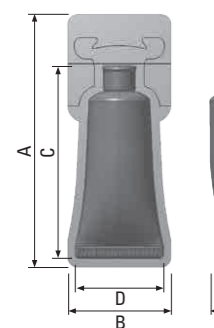

- |          |      |                             |
|----------|------|-----------------------------|
| <b>A</b> | 108  | • Filling capacity : 12.0ml |
| <b>B</b> | 44   | • Multi use                 |
| <b>C</b> | 82   | • Arrangement :             |
|          |      | 1x1 2x1 3x1                 |
| <b>D</b> | 37   | • Printing :                |
| <b>E</b> | 13.2 | Lid - 7 Color printing      |
|          |      | Cavity - 7 Color printing   |

### M023-06

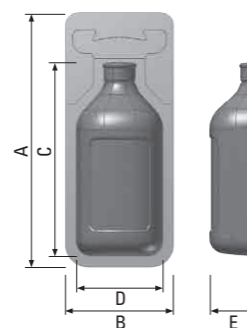

- |          |      |                             |
|----------|------|-----------------------------|
| <b>A</b> | 106  | • Filling capacity : 25.0ml |
| <b>B</b> | 44   | • Multi use                 |
| <b>C</b> | 78.5 | • Arrangement :             |
|          |      | 1x1 2x1 3x1                 |
| <b>D</b> | 35   | • Printing :                |
| <b>E</b> | 19   | Lid - 7 Color printing      |
|          |      | Cavity - 7 Color printing   |

### A016-09(Instant Action Blister-Coin Mask)

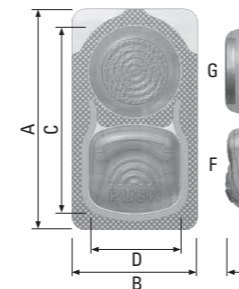

- |          |      |                        |
|----------|------|------------------------|
| <b>A</b> | 67   | • Filling capacity :   |
|          |      | F 4.4ml / G 4.4ml      |
| <b>B</b> | 38   | • Action               |
| <b>C</b> | 57   | • Arrangement :        |
|          |      | 1x1 3x1                |
| <b>D</b> | 28   | • Printing :           |
| <b>E</b> | 12.8 | Lid - 7 Color printing |

### A033-09(Instant Action Blister-Essence Powder)

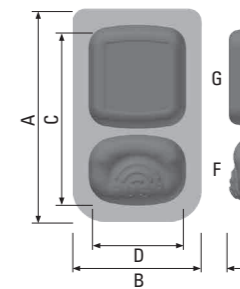

- |          |    |                        |
|----------|----|------------------------|
| <b>A</b> | 66 | • Filling capacity :   |
|          |    | F 4.0ml / G 8.0ml      |
| <b>B</b> | 40 | • Action               |
| <b>C</b> | 56 | • Arrangement :        |
|          |    | 1x1 3x1                |
| <b>D</b> | 30 | • Printing :           |
| <b>E</b> | 14 | Lid - 7 Color printing |





Our innovative packages serve your great success



#### I030-12

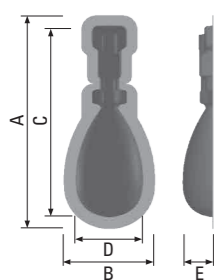

- |          |      |                            |
|----------|------|----------------------------|
| <b>A</b> | 72   | • Filling capacity : 3.0ml |
| <b>B</b> | 30.8 | • Injection                |
| <b>C</b> | 64.5 | • Arrangement :            |
|          |      | 1x1                        |
| <b>D</b> | 22.7 | • Printing :               |
|          |      | Lid - 7 Color printing     |
| <b>E</b> | 10.7 |                            |

#### I044-06

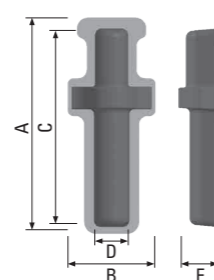

- |          |      |                            |
|----------|------|----------------------------|
| <b>A</b> | 92   | • Filling capacity : 3.5ml |
| <b>B</b> | 38   | • Injection                |
| <b>C</b> | 83.5 | • Arrangement :            |
|          |      | 1x1                        |
| <b>D</b> | 15   | • Printing :               |
|          |      | Lid - 7 Color printing     |
| <b>E</b> | 16.7 | Cavity - 7 Color printing  |

#### I046-06

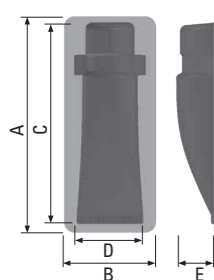

- |          |      |                              |
|----------|------|------------------------------|
| <b>A</b> | 102  | • Applying capacity : 15.0ml |
| <b>B</b> | 43.5 | • Injection                  |
| <b>C</b> | 95.5 | • Arrangement :              |
|          |      | 1x1                          |
| <b>D</b> | 34   | • Printing :                 |
|          |      | Lid - 7 Color printing       |
| <b>E</b> | 18.2 |                              |

#### BLS L002(Lip Card)

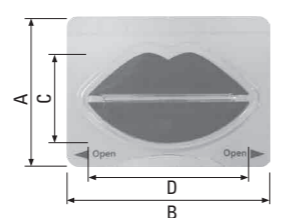

- |          |  |                              |
|----------|--|------------------------------|
| <b>A</b> |  | • Applying capacity : 0.05ml |
| <b>B</b> |  | • Formed PET cover           |
| <b>C</b> |  | • Dimensions (mm) : 57x42    |
| <b>D</b> |  | • Arrangement :              |
|          |  | 1x1                          |
| <b>E</b> |  | • No. of Contents :          |
|          |  | up to 4 Colors               |
|          |  | • Printing :                 |
|          |  | Out Surface - Off-set        |

#### BPW P001(Powder)

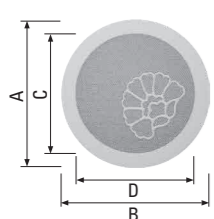

- |          |  |                                  |
|----------|--|----------------------------------|
| <b>A</b> |  | • Applying capacity : 0.1~0.12ml |
| <b>B</b> |  | • Peel-off (Label)               |
| <b>C</b> |  | • Dimensions (mm) :              |
|          |  | Customer's requirements          |
| <b>D</b> |  | • Arrangement :                  |
|          |  | 1x1 2x1 2x2 2x4                  |
| <b>E</b> |  | • No. of Contents :              |
|          |  | up to 4 Colors                   |
|          |  | • Printing :                     |
|          |  | Out / Inner Surface -Off-set,    |
|          |  | Silk printing, Hot stamping &    |
|          |  | Film laminate                    |

#### P001(DY)-09(Aroma Permeable Blister-Air Freshener)

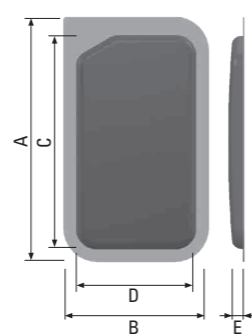

- |          |      |                            |
|----------|------|----------------------------|
| <b>A</b> | 57.3 | • Filling capacity : 2.5ml |
| <b>B</b> | 34   | • Peel-off                 |
| <b>C</b> | 50   | • Arrangement :            |
|          |      | 1x1                        |
| <b>D</b> | 27   | • Printing :               |
|          |      | Lid - 7 Color printing     |
| <b>E</b> | 3.8  |                            |